

# ORWAK FLEX 4240

FLEX

## COMPACT GENERAL WASTE IN 240 L BINS IN OUR NEW WASTE COMPACTOR FLEX 4240!

It is a robust and reliable machine with a compact and lightweight design. Thanks to the small footprint, it takes up little floor space. The 4240 is easy, safe and convenient to use! The multiple-chamber unit offers a top-loading setup, while the single-chamber version is based on the principle "Roll in! Compact! Roll out!".



## Safety



## Orwak benefits

### MORE PRODUCTIVE USE OF TIME

Less time spent on waste handling, more time for your core activities!

### MORE SPACE & ORDER

Our balers rapidly minimizes the space the waste takes up, keeping aisles free and tidy.

### LESS COSTS, MORE VALUE

More compaction = less waste volume to transport. Fewer transports required results in lower transportation costs and reduced CO<sub>2</sub> emissions. Sorting at source yields a higher quality of waste material for recycling.



## Why Orwak Flex?

- + Versatile compaction for many different application areas
- + Hygienic and safe compaction and disposal of mixed or hazardous waste
- + Special solutions for special needs

# ORWAK FLEX 4240

## Smart in-bin compaction solution

### ORWAK FLEX 4240 IS OPTIMIZED FOR:

#### SEMI-DRY WASTE

+ General waste

*Best suited for dry or semi-dry waste destined for landfill or incineration*

ORWAK FLEX 4240 is an in-bin waste compactor for standard two-wheeled 240 L bins.

#### IDEAL FOR GENERAL WASTE

The 4240 is perfect for the hotel and restaurant sector, where general waste needs to be disposed of in waste bins. The in-bin compactor provides impressive volume reduction, contributing to valuable space-saving and a more profitable waste management.

#### SAFE AND USER-FRIENDLY

Model 4240 is user-friendly! The multi-chamber version is a convenient top-loading installation, while the single-chamber version has an easy wheel-in, wheel-out operation. Safety and quality are our hallmarks and the compactor provides maximum personal safety both for the operator and those in the immediate vicinity. A bin indicator assures that the machine can only start, when the bin is in the right position.



Designed to fit the standard 240 Liter bins in the market.

#### SMART DESIGN - EASILY EXTENDABLE

The 4240 is a robust and stable machine that, thanks to its compact design, occupies little floor space. A good finish and easy access make cleaning quick and simple.

The compactor is easily extended with additional chambers. The front door on the single-chamber unit is then replaced by an apron for effortless movement of the press head from one chamber to the next.

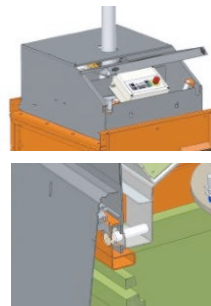

Full protection and no access to moving parts: safety switches on the hatch and the front door/apron



The single-chamber unit with swing door



The multiple-chamber unit equipped with an apron with two handles

## DIMENSIONS & SPECIFICATIONS

### DIMENSIONS ORWAK FLEX 4240

A	B	C	D	TRANSPORT HEIGHT
Single: 2275 mm	Single: 750 mm	Single: 920 mm	Single: 1515 mm	Single: 2100 mm
Double: 2275 mm	Double: 1475 mm	Double: 990 mm		Double: 2100 mm

### MACHINE WEIGHT

TOTAL WEIGHT	PRESS UNIT	SINGLE STAND
Single: 220 kg	Single: 120 kg	Single: 100 kg
Double: 320 kg	Double: 120 kg	Double: 100 kg

### TECHNICAL SPECIFICATIONS

BIN SIZE	CYCLE TIME	PRESS FORCE	NOISE LEVEL	PROTECTION CLASS	OPERATING POWER
240 L	29 secs	1.5 ton, 15 kN	62.3 db (A)	IP 55	1 x 230 V, 50 Hz, 10 A or 3 x 200 V, 50/60 Hz, 10 A

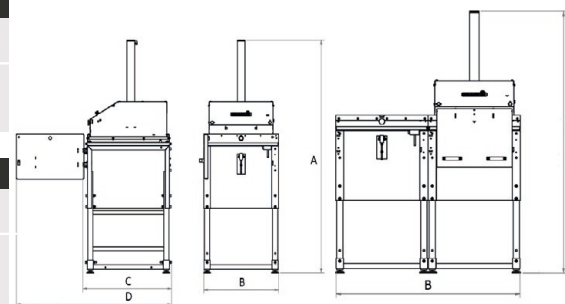

We reserve the right to make changes to specifications without prior notice. Bale/bag/bin weights are dependent upon material type.

### Interzero Circular Solutions Europe GmbH

BIZ ZWEI – Vorgartenstraße 206 C

1020 Wien, AUSTRIA

Tel: +43 1 7142005 5800

E-Mail: [orwak@interzero.at](mailto:orwak@interzero.at)

[www.interzero.at](http://www.interzero.at)

